

Enevator Aqua Booster

Water/water heat pump

Water-water heat pump for high temperature



- Specifically suitable for use with source water supply from Chiller or potable water storage tanks
- High maximum temperatures up to 70°C
- COP up to 4.94
- Low noise
- Refrigerant R134a

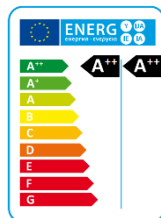

Technical Specifications

Model		WWHB 30	WWHB 40	WWHB 60	WWHB 70	WWHB 90
Heating capacity (EN14511) ⁽¹⁾	kW	38,8	46,0	58,4	70,3	88,4
Input power (EN14511) ⁽¹⁾	kW	8,2	9,4	11,8	14,8	18,8
COP (EN14511) ⁽¹⁾	W/W	4,73	4,85	4,93	4,76	4,70
Energy Class in low temperature ⁽²⁾		A+++	A+++	A+++	A+++	A+++
SCOP low temperature ⁽²⁾	kWh/kWh	4,85	5,00	5,16	5,00	5,08
ηs,h low temperature ⁽²⁾	%	185,9	192,1	198,2	191,8	195,3
Energy Class in medium temperature ⁽²⁾		A++	A++	A++	A++	A++
SCOP medium temperature ⁽²⁾	kWh/kWh	4,07	4,19	4,28	4,18	4,16
ηs,h medium temperature ⁽²⁾	%	154,8	159,6	163,0	159,0	158,3
Power supply	V/Ph/Hz	460/3/60	460/3/60	460/3/60	460/3/60	460/3/60
Maximum input current	A	128,7	137,6	168,0	209,0	266,0
Peak current	A	35,4	39,2	56,0	70,0	82,0
Compressors / Circuits	n°/n°	2/1	2/1	2/1	2/1	2/1
Capacity steps	n°	2	2	2	2	2
Refrigerant		R134a	R134a	R134a	R134a	R134a
Global warming potential (GWP)		1430	1430	1430	1430	1430
Refrigerant charge	kg	2,0	2,0	3,0	3,0	4,0
Equivalent CO2 charge	t	2,9	2,9	4,3	4,3	5,7
Sound power	dB(A)	65	65	70	73	74
Sound pressure	dB(A)	49	49	54	57	58

Model		WWHB 120	WWHB 140	WWHB 180	WWHB 230	WWHB 260
Heating capacity (EN14511) ⁽¹⁾	kW	109,9	136,5	176,9	219,5	273,2
Input power (EN14511) ⁽¹⁾	kW	23,1	27,9	37,2	45,7	55,3
COP (EN14511) ⁽¹⁾	W/W	4,75	4,88	4,75	4,80	4,94
Energy Class in low temperature ⁽²⁾		A+++	A+++	A+++	A+++	A+++
SCOP low temperature ⁽²⁾	kWh/kWh	5,17	5,36	5,29	5,38	5,56
ηs,h low temperature ⁽²⁾	%	198,9	206,3	203,4	207,0	214,4
Energy Class in medium temperature ⁽²⁾		A++	A++	A++	A++	A++
SCOP medium temperature ⁽²⁾	kWh/kWh	4,22	4,35	4,27	4,34	4,47
ηs,h medium temperature ⁽²⁾	%	160,9	165,9	162,8	165,6	170,7
Power supply	V/Ph/Hz	460/3/60	460/3/60	460/3/60	460/3/60	460/3/60
Maximum input current	A	324,0	372,5	348,0	428,0	497,5
Peak current	A	104,0	125,0	164,0	208,0	250,0
Compressors / Circuits	n°/n°	2/1	2/1	4/2	4/2	4/2
Capacity steps	n°	2	2	4	4	4
Refrigerant		R134a	R134a	R134a	R134a	R134a
Global warming potential (GWP)		1430	1430	1430	1430	1430
Refrigerant charge	kg	5,0	6,0	8,5	10,5	13,0
Equivalent CO2 charge	t	7,2	8,6	12,2	15,0	18,6
Sound power	dB(A)	76	78	88	89	91
Sound pressure	dB(A)	60	62	72	73	75

Performances are referred to the following conditions:

- (1) Heating: Ambient temperature 7°C DB, 6°C WB, water temperature 30/35°C.
 (2) Average conditions, variable - Reg EU 811/2013

(3) Sound power level in accordance with ISO 3744

(4) Sound pressure level at 10 mt from the unit in free field conditions in accordance with ISO 3744

Frame

All units are made from hot-galvanized sheet steel, painted with polyurethane powder enamel, and stoved at 180°C to provide maximum protection against corrosion. The frame is self-supporting with removable panels. All screws and rivets used are made from stainless steel. The standard color of the units is RAL 9018.

Refrigerant circuit

The refrigerant utilized is R134a. The refrigerant circuit is assembled using internationally recognized brand name components with all brazing and welding being performed in accordance with ISO 97/23. Each refrigerant circuit is totally independent from the other with the result that any fault or alarm condition on one circuit does not influence the other. The refrigerant circuit includes sight glass, filter drier, thermal expansion valve with external equalizer, Schrader valves for maintenance and control and pressure safety device (for compliance with PED regulations)

Microprocessors

All units are supplied as standard with microprocessor controls. The microprocessor controls the following functions: control of the water temperature, antifreeze protection, compressor timing, compressor automatic starting sequence, alarm reset, volt free contact for remote general alarm, alarms, and operation LED's. If required (available as an option), the microprocessor can be configured for it to connect to a site BMS system thus enabling remote control and management. The technical department can discuss and evaluate, in conjunction with the customer, solutions using MODBUS protocols.

Compressors

The compressors used are a high-performance scroll type that incorporates a special scroll design which enhances the efficiency of the refrigerant cycle when the source temperature is low. The compressors are all supplied with a crankcase heater and thermal overload protection by a klixon embedded in the motor winding. They are mounted in a separate enclosure thus enabling them to be maintained even if the unit is operating. Access to this enclosure is via the front panel of the unit. The crankcase heater is always powered when the compressor is in stand-by.

Source heat exchanger

Source heat exchanger are braze-welded plates and are made of stainless steel AISI 316. The use of this type of exchangers greatly reduces the refrigerant charge of the unit compared to the conventional shell and tube evaporators and increases the efficiency of the refrigerant loads. The heat exchangers are factory insulated with flexible close cell material and are protected by a temperature sensor used as antifreeze protection kit.

User exchanger

The user side heat exchanger is a braze welded, plate type heat exchanger, manufactured from AISI 316 stainless steel. All units are supplied with a sub-cooler to enhance the performance of the refrigerant cycle. The user heat exchangers are factory insulated with flexible close cell material.

Electric enclosure

The enclosure is manufactured to comply with the requirements of the electromagnetic compatibility standards CEE EN60204. Access to the enclosure is achieved by removing the front panel of the unit. The following components are supplied as standard on all units: main switch, thermal overloads (protection of pumps and fans), compressor fuses, control circuit automatic breakers, compressor contactors, fan contactors and pump contactors. The terminal board has volt free contacts for remote ON-OFF, Summer/Winter change over (reversible type only) and general alarm. For all three phase units, a sequence relay that disables the power supply if the phase sequence is incorrect (scroll compressors can be damaged if they rotate in the wrong direction), is fitted as standard.

Control and protection devices

All units are supplied with the following control and protection devices: Return and supply user heat exchanger sensors, return and supply source heat exchanger sensors, high pressure switch with manual reset, low pressure switch with automatic reset, high pressure safety valve, compressor thermal overload protection, pump thermal overload protection (when present), source heat exchanger flow switch.

Super low noise version

All units in are supplied, as standard, with the latest 'Floating Frame' technology that completely isolates the compressors from the main casing, thereby eliminating vibration and noise from this source. The 'Floating Frame' is a special vibration and acoustic damping system that consists of a base plate and acoustic enclosure that houses the compressors. The base plate is separated from the supporting frame of the unit by soft steel springs that have a high damping power. Within the enclosure, the compressors are mounted on rubber shock absorbers on the floating base plate. The enclosure is manufactured from galvanized steel sandwich panels that have a micro-perforated inner skin and a core of 50 mm thick, high density (40 kg/m³) mineral wool. The entire arrangement provides a double damping system and acoustic attenuation. The compressor refrigerant pipes are connected to the refrigerant circuit through "anaconda" flexible connections. Flexible connections are also used on the water pipework within the unit. The combination of these systems results in an overall noise reduction in the region of 10-12 dB(A)

Dimensions

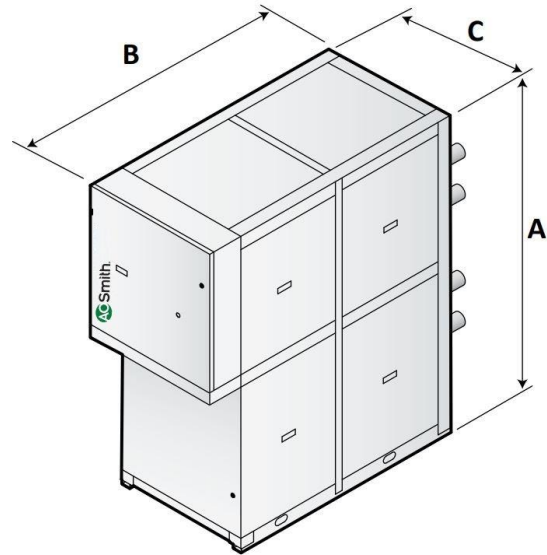
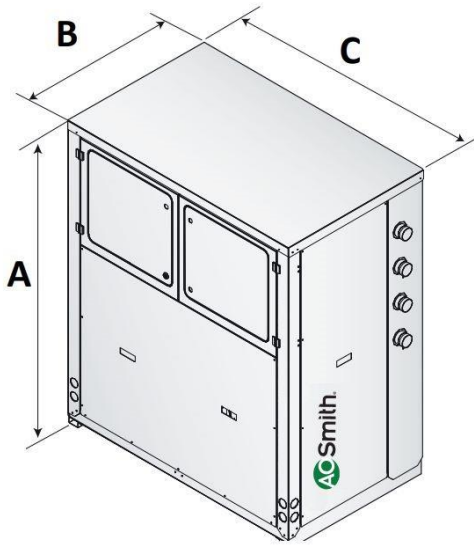

Model	A (mm)	B (mm)	C (mm)	kg
WWHB 30	1600	800	1150	660
WWHB 40	1600	800	1150	660
WWHB 60	1600	800	1150	700
WWHB 70	1600	800	1150	730
WWHB 90	1600	800	1150	740
WWHB 120	1600	800	1150	760
WWHB 140	1600	800	1150	790

Model	A (mm)	B (mm)	C (mm)	kg
WWHB 180	1900	3120	800	1320
WWHB 230	1900	3120	800	1390
WWHB 260	1900	3120	800	1430